



Referência: 820
 Linha: Laser
 Categoria: Pendente
 Descrição: Pendente Laser REF 820
 Dimensões:
 • Altura: 15cm
 • Largura: 50cm
 • Profundidade: 50cm

Peso: 3.200g
 Material: Lâmina natural de madeira, MDF, Acrílico, Cabos de aço







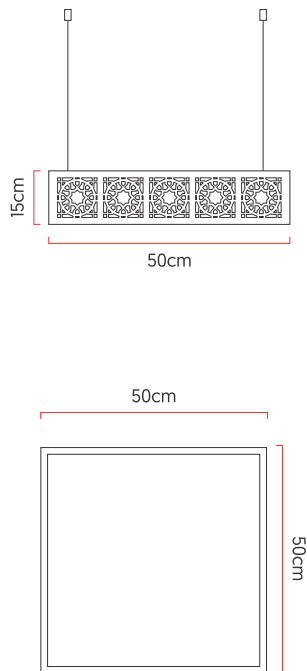

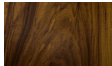

Soquete: E27 4x (25W max. cada) Fluorescente ou LED lâmpadas não inclusa
 Temperatura de Cor: De acordo com a lâmpada
 CRI: De acordo com a lâmpada
 Fluxo Luminoso: De acordo com a lâmpada
 Lumens Entregue: De acordo com a lâmpada
 Potência Total: De acordo com a lâmpada

Tensão de Entrada: 110V - 220V
 Frequência de Entrada: 60 Hz
 Isolamento: Classe II
 Proibido o uso de lâmpadas incandescente

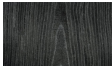
Cabos de sustentação padrão 200cm (outras medidas consulte-nos)

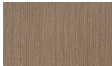

Opções de acabamentos

	01 Madeira Imbuia		02 Madeira Freijo
	03 Madeira Nogueira		04 Madeira Teca
	05 Madeira Pinus		06 Madeira Ébano
	07 Madeira Ébano Macassar		08 Madeira Platinum
	09 Madeira Rovere		10 Madeira Nogueira Linheira
	11 Madeira Cinamomo		12 Madeira Pau Ferro